



## Masterlift 2.40 NxT Pv & NxT TR Pv

Electro-hydraulic twin-ram lift, 4 t  
with repair platforms

NxT Generation - Inground lifts



NxT Generation



**The highlights of the Masterlift 2.40 NxT Pv & NxT TR Pv:**

- Stable and slim repair platforms
- Length adjustable due to flat slider
- Ø140 mm cylinder: strong, low-maintenance, durable
- Control: modern, reliable, intuitive operation

**Exactly the right choice for you!**

## What's underneath should excite you just as much as what's on it.

### Masterlift 2.40 NxT Pv & NxT TR Pv:

The Masterlift 2.40 NxT Pv repair platform is optimally suited for **quick and easy vehicle lifting**. The premium version is constructed of very strong and rigid **solid steel** that offers a **high degree of stability**. They are zink coated and painted. Looks great and works great!

The **handy, non-slip and form-fitting rubber pads** ensure that the vehicle is lifted with pinpoint accuracy.

The **strong 140 mm diameter cylinders** are also designed for long-lasting functionality and further round off the high quality level, which ensures **low maintenance requirements**.

Even in the event of a power blackout, the lift can still be lowered without any problems thanks to the pneumatic emergency lowering system. The Masterlift 2.40 NxT Pv & NxT TR Pv are perfectly completed by a **control system that is both visually and technically convincing**.

# Masterlift 2.40 NxT Pv

Electro-hydraulic twin-ram lift, 4 t with repair platforms

Synchronisation and safety via synchronisation bar

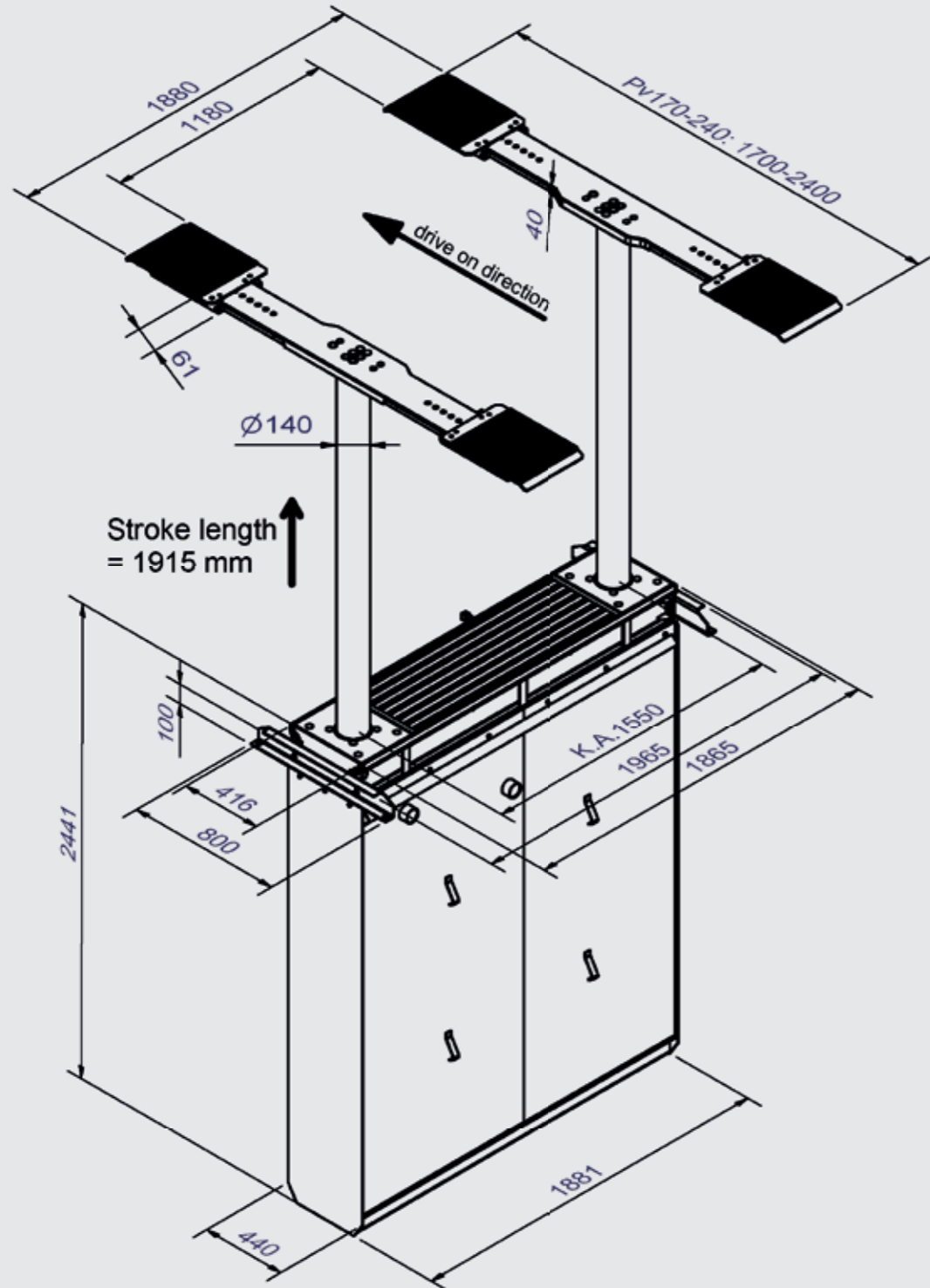

Illustrations are not binding and optional. Under reserve of dimensional, constructional and technical modifications! Validity 01/2025.

# Masterlift 2.40 NxT Pv

## Technical data

Lifting capacity	4000 kg
Stroke length	1915 mm
Working height	1980 mm + rubber pads
Cylinder diameter	2 x 140 mm
Cylinder distance	1550 mm
Lifting / Lowering time	~ 30 sec.
Foundation depth	2640 mm
Pump unit	3.0 kW
Hydraulic fluid	10 l
Voltage	230/400 V / 50 Hz / 16 A

### Standard colour:

- Pv Premium: zink coated and painted - RAL 7016

### Options:

- Rubber blocks in different heights
- Active cassette ventilation
- Moisture monitoring in the steel cassette

### Variants:

- Self-supporting design, without load on the bottom of the cassette
- Floor-standing design

## Pv superstructure

Total length, min.-max.	170-240: 1700 - 2400 mm
Drive-over height	65 mm

### Installation variants:

- On-floor installation
- Ceiling installation

### Frame:

- Standard: completely hot-dip galvanized
- Stainless steel tile frame

### Sub-casing:

- Standard: painted
- Optional: hot-dip galvanized or plastic-coated



# Masterlift 2.40 NxT Pv TR

Electro-hydraulic twin-ram lift, 4 t  
with repair platforms

Synchronisation and safety via toothed rack and cardan shaft

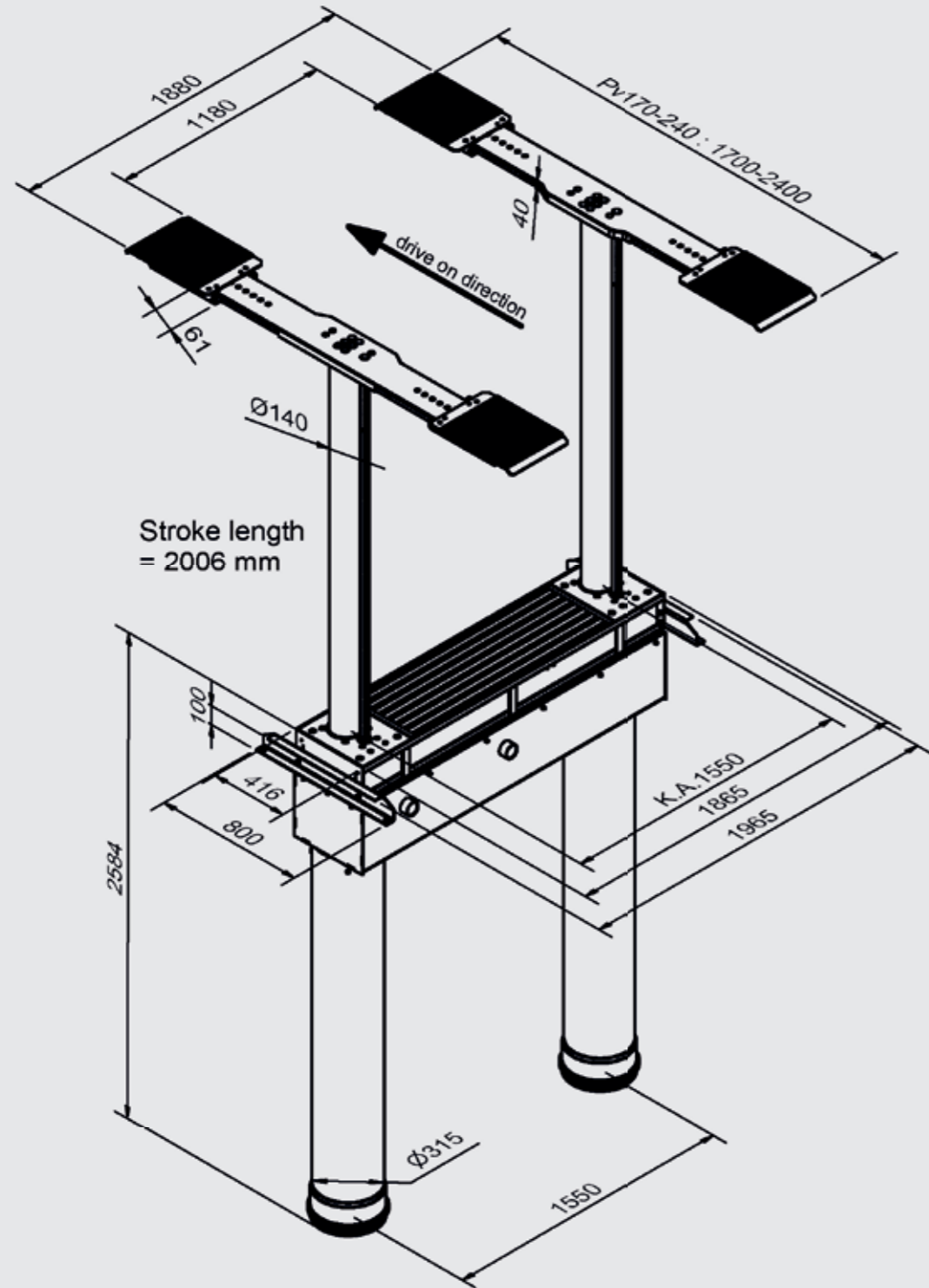

Illustrations are not binding and optional. Under reserve of dimensional, constructional and technical modifications! Validity 01/2025.

# Masterlift 2.40 NxT Pv TR

## Technical data

Lifting capacity	4000 kg
Stroke length	2006 mm
Working height	2071 mm + rubber pads
Cylinder diameter	2 x 140 mm
Cylinder distance	1550 mm
Lifting / Lowering time	~ 30 sec.
Foundation depth	800 mm
Pump unit	3.0 kW
Hydraulic fluid	10 l
Voltage	230/400 V / 50 Hz / 16 A

### Standard colour:

- Pv Premium: zink coated and painted - RAL 7016

### Options:

- Rubber blocks in different heights

### Standard:

- Basically self-supporting design

## Pv superstructure

Total length, min.-max.	170-240: 1700 - 2400 mm
Drive-over height	65 mm

### Installation variants:

- On-floor installation
- Ceiling installation

### Frame:

- Standard: completely hot-dip galvanized
- Stainless steel tile frame
- Incl. primed tube connection frame



[www.autopstenhoj.com](http://www.autopstenhoj.com)



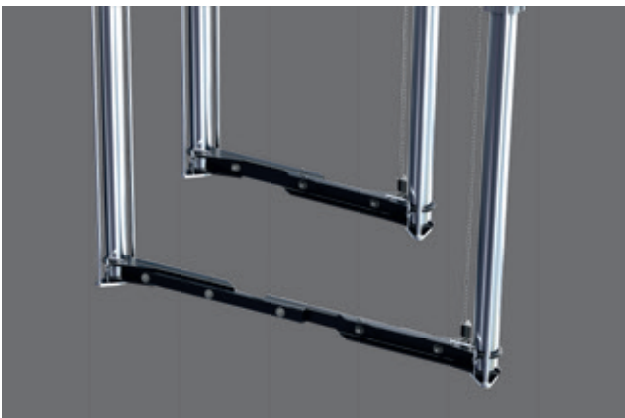
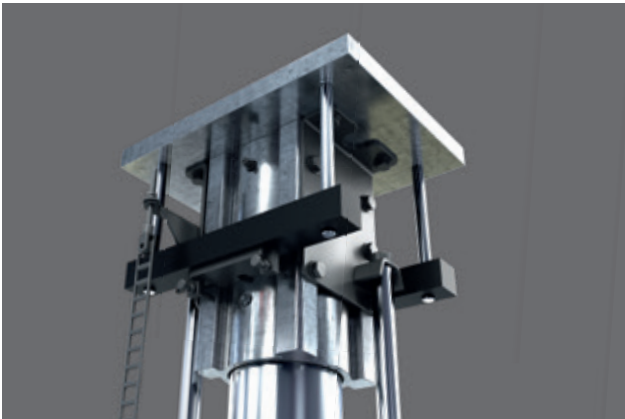

## And even more highlights: Inground technology reinvented!

With the **NxT Generation** inground lifts from AUTOPSTENHOJ you experience quality at the very highest level! We have made the best even better for you!

**NxT Generation inground lifts:** Flexible in installation and operation, also adaptable to possible, changing requirements in the future, due to our smart clamping system.

Synchronisation takes place either via a synchronisation bar or alternatively via a toothed rack. We achieve maximum stability through strong 140 mm cylinders and through our new aluminium guidance made of anodised solid material. With the new cassette cover, even strong forces acting on the cover during battery removal, for example, are safely absorbed.

The complete, sophisticated system gets by with only 10 litres of hydraulic fluid, thanks to proven high-pressure technology. Those who have the environment in mind should not disregard this fact.

The **NxT Generation inground lift** is suitable for all installation variants and thus, of course, also for self-supporting installation. The **NxT Generation inground lifts** are also always a good choice for replacement campaigns or retrofitting in third-party cassettes.

**NxT Generation: Patented, flexible, modular**

